



ALS Safe Support Backrest & Pad (ALSSSBV1)

by Anti Ligature Shop

Ideal replacement for Doc M backrest where a reduced ligature design is required:

Product Features

- Extremely tough 1.2mm mild steel housing, stainless steel version available on request
- White or blue antibacterial powder coating (see specification below)
- Angular design resists ligature attachment
- Comfortable well-padded cushioned back support is made from a fire retardant foam and covered with a ripstop vinyl which is seam welded to resist water penetration
- The pad is self-supported within a recess but can easily be removed for cleaning (NB: Pad adheres to recessed housing using magnetic attraction)

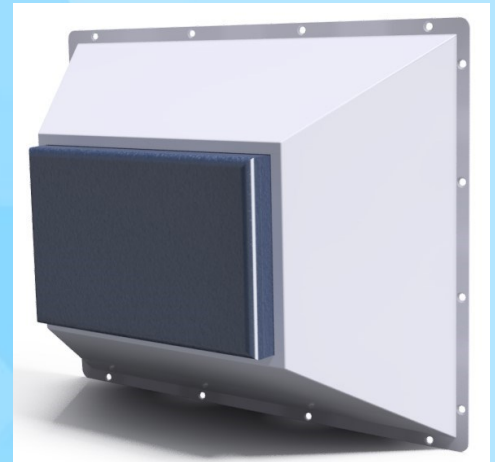

Installation

- Supplied with 1 ¼ " size 8 six lobe pin security screws
- Recommended to be fitted using a bead of anti-pick around the edge (i.e. ANTIP109 in white or grey)

Cleaning

- Use mild detergent on a damp cloth

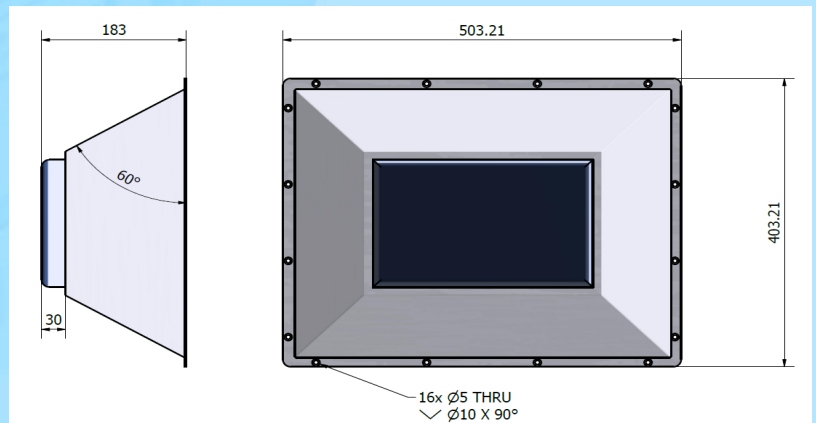

NBS Specification

The anti-ligature design features of this product are not intended to replace or substitute the need for necessary supervision of those who may be at risk, or for other necessary protective measures to be taken in the specific circumstances of usage.. Anti-Ligature Shop does not claim any product to be totally ligature free ofr make claim that they cannot be damaged with regard to anti-vandal feature. It is therefor the customers responsibility to ensure the suitability of the product for the environment in which they are to be fitted.

Call: 03300 536020

Email: 03300 536020

Visit: www.anti-ligature-shop.co.uk

51 Haydock Street | Soteria House | Bewsey & Whitecross
| Warrington | Cheshire | WA2 7UW

