

KWC DVS

ANMX

EN

Installation, use and maintenance handbook

ANMX 308
ANMX 309
ANMX 311
ANMX 312



CONFORMANCE STATEMENT

This appliance has been manufactured with suitable materials for use with drinking water.

The device conform to L.D. 108 dated 25.01.1992. (87/308/CEE) **CE** and has been approved by the WRAS (WATER REGULATION ADVISORY SCHEME) **WRAS** APPROVED PRODUCT.

This product has been designed, manufactured and placed on the market complying with the following EC conformities:

- Safety objectives of the "Low Voltage" of Directive 2014/35/UE (Ex 2006/95/EEC).
- Protection requirements of Directive, 2014/30/UE (Ex 2004/108/EEC).

APPLIANCE DATA PLATE

1	Model
2	Supply voltage
3	Quantity of cooling gas
4	Class
5	Total absorption
6	Frequency
7	Serial number
8	Construction year-month

EN 1 BEFORE USING THE APPLIANCE

1.1 WARNINGS

In order to use your appliance to its best, we advise reading these instructions carefully as they contain useful information.

- Keep this book for later use.
- When you have removed the packaging, make sure that the appliance is not damaged. Any damage must be reported to your carrier within 24 hours.

If the machine has been put down or turned upside down, wait for at least 8 hours before putting it into operation.

- Make sure that installation and electrical wiring are carried out by a qualified technician according to the manufacturer's instructions and to the local norms in force. The electrical system must be equipped with an effective earth according to the law (46/90).

1.2 GENERAL PRECAUTIONS AND SUGGESTIONS

Before carrying out any maintenance or cleaning operation, remove the plug from the mains socket.

- Do not pull on the supply cable in order to remove the plug from the socket.
- When the appliance has been installed, make sure it is not resting on the mains supply cable.

The data and characteristics indicated in this manual do not bind the manufacturer, who reserves the right to make all the modifications deemed necessary, without having to give prior notice or replacement.

Failure to comply with any of these safety regulations could cause fires, electric shocks or damage the machine.

PLACE OF INSTALLATION

- This appliance is designed for household and similar uses such as:
 - Kitchen areas of personnel in shops, offices and other working environments;
 - Rural houses and hotel customers, motels and other residential type environments;
 - Areas like bed & breakfast and guest houses;
 - Food services and use at similar retailers.

- Do not place the machine near inflammable solvents such as alcohol or diluents.
- Do not install the machine in excessively damp and dusty places, exposed to direct sunlight, outdoors or near to heat sources. Machine installation in these places could cause fires or electric shocks.
- The appliance is not suitable for use in open places.
- During connection of the appliance to the mains water supply, all pre-existing tubes, gaskets and joints placed between the appliance and the water mains connection must be replaced with new material to avoid contamination.
- No obstructions the ventilation openings.

ELECTRIC POWER SUPPLY

- Do not connect or disconnect the machine from the socket with wet hands.
- Insert the plug into the wall socket firmly.
- Do not damage, modify, stretch, bend or twist the power cable.
- Do not place heavy objects on the power cable.
- Do not connect the machine to a socket to which other equipment is connected (extensions, 2 or 3 plug adaptors, etc.).
- Do not use the machine if the power cable is tied or knotted.
- If smoke, unusual smells or strange noises are found coming from the machine, disconnect it immediately from the socket and contact the local retailer or technical service assistance. Use of the machine in these conditions could cause fires or electric shocks.
- Periodically disconnect the machine from the socket and clean the plug and socket with a dry cloth. If the machine is connected in a place exposed to dust, smoke or high humidity, the dust accumulated on the plug will absorb humidity and this could after the insulation and trigger a fire.
- Do not spray water on the device; this could cause electric shocks or fires.
- The appliance must not be installed where water jets can be generated.
- Use a damp cloth to clean the machine. Do not use inflammable solvents such as alcohol, benzene or diluents. If inflammable substances come in contact with the electrical components inside the machine, they can cause fires or electric shocks.
- Before cleaning the machine, switch it off and disconnect it from the socket. Not being switched off or accidental switching on during cleaning could cause injuries to persons or damages to the machine.
- The device can be used by children under the age of 8 and by people with reduced physical, sensory or mental capabilities, or lack of experience or knowledge, provided under supervision or after the same have been instructed on the use ensure safe and understanding of the dangers inherent in it. Children should not play with the appliance. Cleaning and maintenance meant to be performed by the user must not be performed by unsupervised children

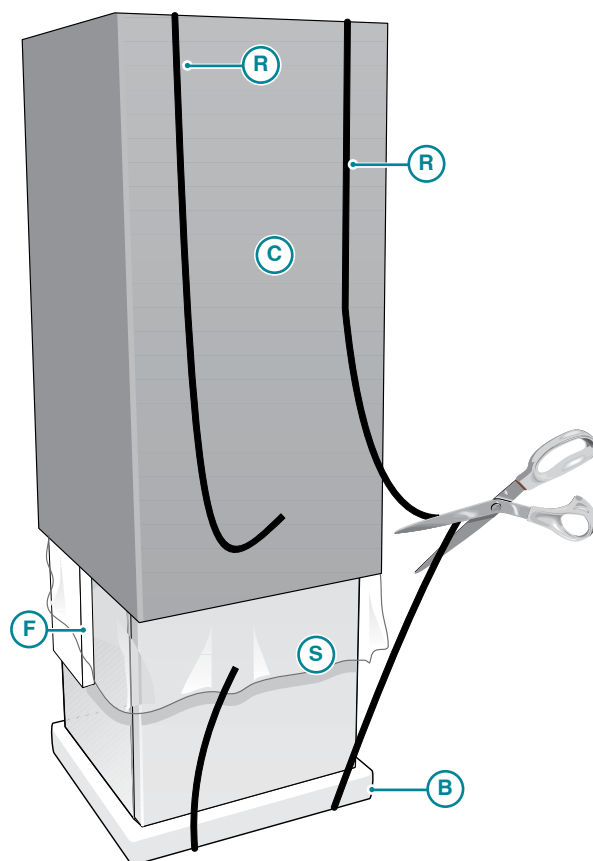

EN 2 REMOVAL OF PACKAGING

- Place the appliance in its installation site (chap. 5 - INSTALLATION).
- Cut straps **R** and remove carton **C**, polystyrene **F** and external plastic bag **S**.
- Do away with plastic bags **S** and polystyrene **F** immediately as they are a danger for children.
- Once the appliance is free from its packaging, remove the base **B**.

2.1 ADVICE ON HOW TO PROTECT THE ENVIRONMENT Packaging

Packaging material is 100% recyclable.

For its disposal follow your local regulations.

The packaging material (plastic bags, polystyrene parts etc.) must be kept out of children's reach as it could be dangerous.

Information

This appliance does not contain CFCs (the cooling circuit contains a gas that is not harmful to the ozone layer).

For further details, please refer to the serial data plate on the appliance.

Product

This appliance is marked according to the European directive 2012/19/UE on Waste Electrical and Electronic Equipment (WEEE). By ensuring this product is disposed of correctly, you will help prevent potential negative consequences for the environment and human health, which could otherwise be caused by inappropriate waste handling of this product.



The symbol on the product, or on the documents accompanying the product, indicates that this appliance may not be treated as household waste. Instead it shall be handed over to the applicable collection point for the recycling of electrical and electronic equipment.

Disposal must be carried out in accordance with local environmental regulations for waste disposal. For more detailed information about treatment, recovery and recycling of this product, please contact your local city office, your household waste disposal service or the shop where you purchased the product.

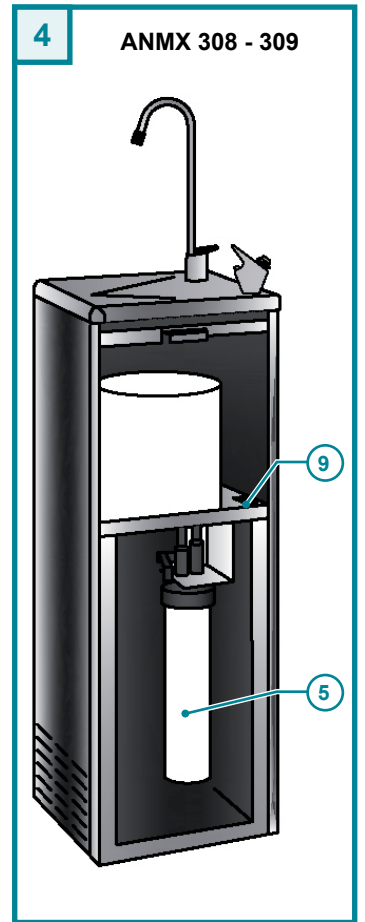
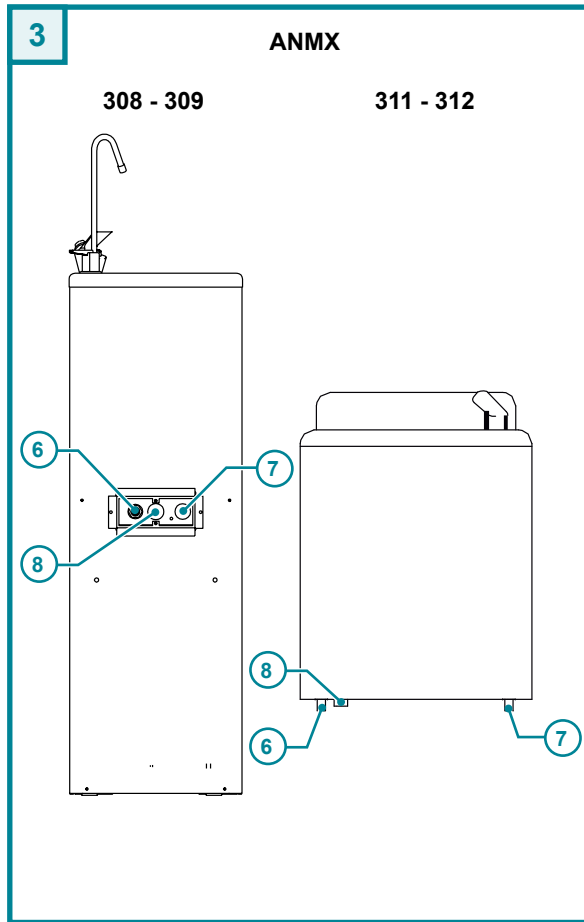
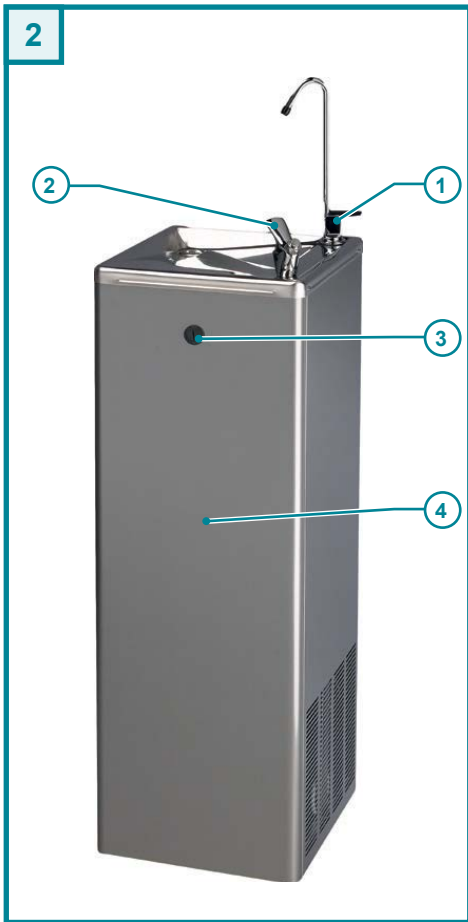

EN 3 DESCRIPTION OF THE APPLIANCE

These water coolers were designed to offer maximum hygiene and easy maintenance.

They are sturdy and have a high level of performance.

The direct cooling system (made from non-oxidising steel aisi 316L) guarantees an optimal hygiene for factories, offices, communities and public places.

The machine must be connected to a source of potable water and fitted with special filtering kits.

The machine must be installed in a room where the environmental conditions are as specified in the chapter "TECHNICAL CHARACTERISTICS".

- 1 **G61 valve (ANMX 309 & 312)**
- 2 **G62 valve**
- 3 **Door closure**
- 4 **Door**
- 5 **Water filter**
- 6 **Water inlet ø8 mm**
- 7 **Power connection**
- 8 **Water outlet**
- 9 **Temperature control Thermostat**
- 10 **Bracket for Wall**

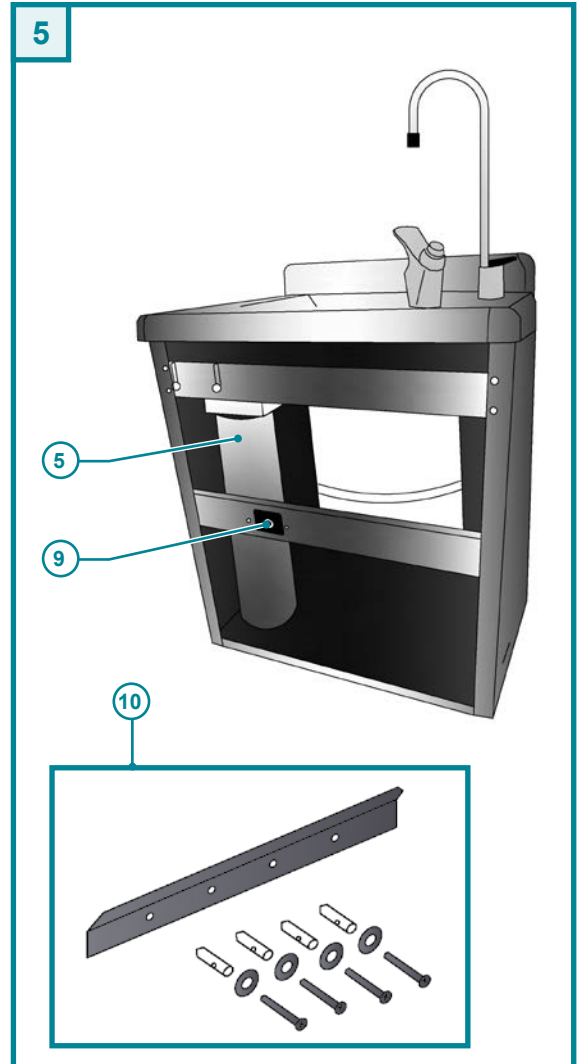

		6			ANMX RANGE	
					ANMX 308 - 309	ANMX 311 - 312
Water production	Lt/h usg			25 6,6	25 6,6	
Water outlet temperature	°C °F			8 ÷ 12 46 ÷ 53	8 ÷ 12 46 ÷ 53	
Compressor	HP			1/6	1/6	
Rated input	Watt			190	190	
Packing dimensions	mm			40x42x106 (V. 0,18)	51x44,5x67 (V. 0,18)	
Net weight	kg lbs			29 63,9	26 57,3	
Gross weight	kg lbs			31 68,3	27 59,5	
Charge	FREON R134A g oz			100 3,5	100 3,5	

4.1 CONDITIONS OF THE SURROUNDINGS

ROOM TEMPERATURE:	Min 10°C Max 45°C
-------------------	----------------------

HANDBOOK SECTION II
Reserved to qualified operators

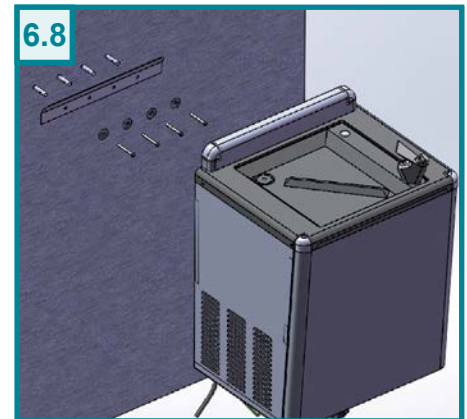
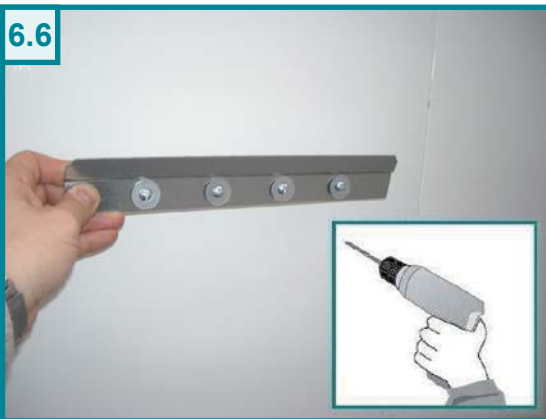
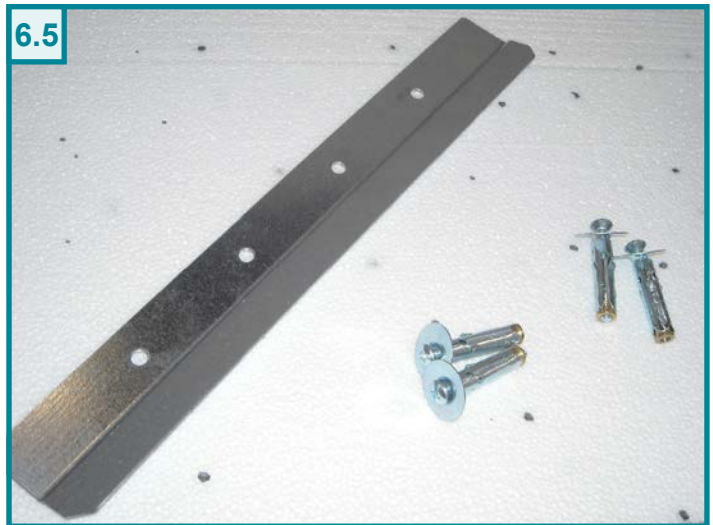
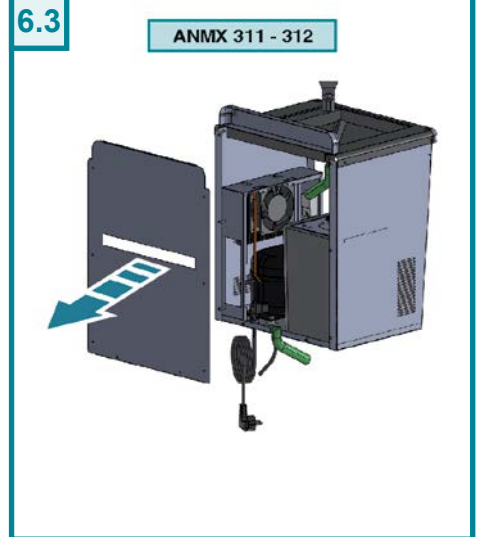
**Attention:**

To carry out this or any other maintenance operation requiring the machine casing to be opened, use protective gloves to avoid being cut by the sharp edges of the sheet steel.

EN 5 INSTALLATION

Place the appliance in the desired point of installation, away from heat sources and protected from direct sunrays.

- Adjust foot 1 to level the appliance correctly and to avoid irritating noises caused by vibration (Fig. 7).

The device must not be used outside or in wet environments.

5.1 POSITIONING THE UNIT

- When handling and moving the cooler, use the handle recessed into the cross support on the back of the unit.
- To ensure proper ventilation, position the cooler at a distance of at least 6-7 cm from the wall.

5.2 ANMX 311 - 312

Unscrew the rear panel in order to get the power cord and pipes (Fig. 6.3). Eventually replace the rear panel.

The wall fixing of ANMX 311 - 312 (Fig. 6.8) requires the following steps:

- Apply a silicon film on the rear side of the cooler (Fig. 6.4).
- In the installation kit there's a metal bracket and four screws (Fig. 6.5). If the wall is in particular material (wood, plaster), property screws are required. Look for them in a dedicated shop.
- Apply the bracket to the wall (Fig. 6.6).
- Positioning the cooler to the wall, keep the bracket in contact with the opening **A** on the rear side of the cooler (Fig. 6.7).

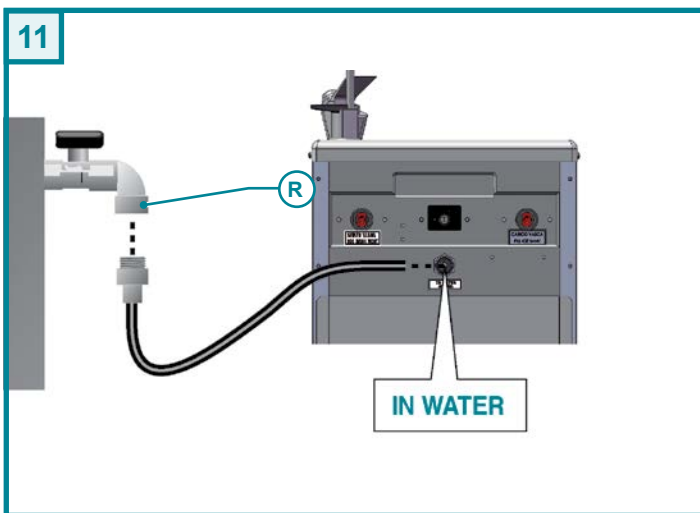
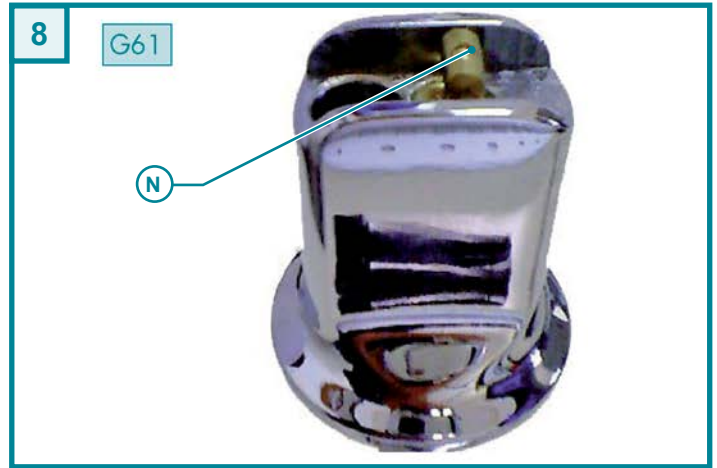
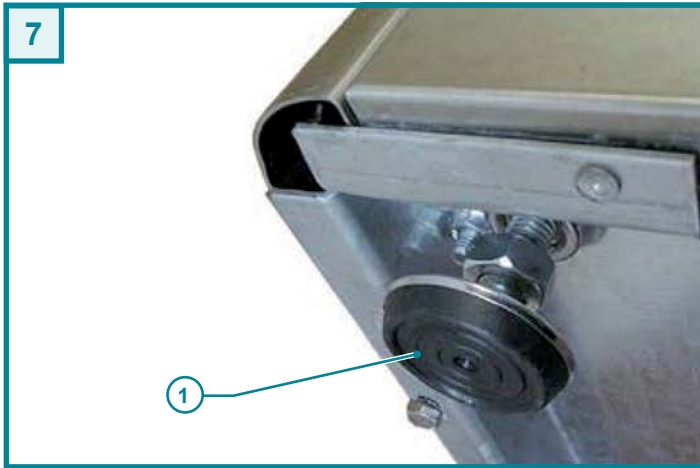

EN 5 INSTALLATION

5.2 ASSEMBLY AND ADJUSTMENT OF THE FAUCETS

Faucet G61 - Insert the lever and let it glide on the specific guiding channel, attach the tube, and tighten it. The water flow is pre-set by the manufacturer. If it needs to be adjusted, manipulate ratchet **N** (Fig. 8), tighten it to increase the flow, loosen it to decrease it. Only carry out one revolution at a time.

Faucet G62 (Fig. 9) - The faucets **G62** are always assembled. To regulate the water flow, remove ferrule **G** and manipulate screw **V**. Turning it clockwise will decrease the flow, anticlockwise movement will increase it.

Faucet G63 (Fig. 10) - This faucet is being controlled by a pedal, which must be attached with a trigger device at the predetermined location. The water flow is regulated by manipulating screw **S**: turning it clockwise will decrease the flow, anticlockwise movement will increase it.

5.3 WATER CONNECTION TO THE MAINS

Before making the water connection, make sure the mains water pressure

is between 1 and 3 bars:

- If the mains water pressure exceeds 3 bars, predispose a pressure reducer capable of reducing the latter to the 1-3 range (Fig. 12).
- Connect the appliance to the water mains using the water inlet fitting **I** (Fig. 11).

ANMX 308 - 309

- The 3/8F connector or the fast coupling provided can be used for the 8 mm diameter pipe.

ANMX 311 - 312

- Connect with an 8 mm pipe.
- Predispose a stop tap **R** on the water inlet pipe.



During connection of the appliance to the mains water supply, all preexisting tubes, gaskets and joints placed between the appliance and the water mains connection must be replaced with new material to avoid contamination.

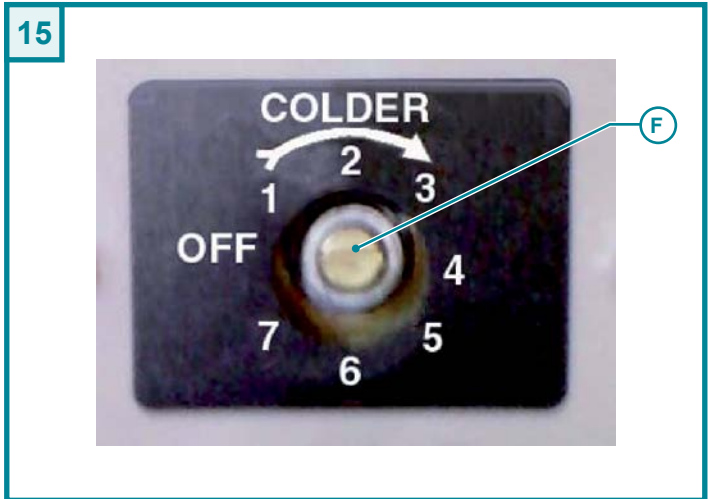
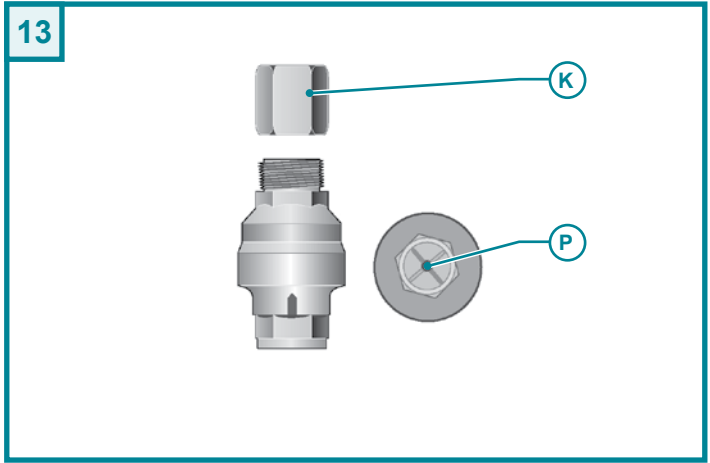

Connect the machine to a mains electrical network protected by a circuit breaker with a sensitivity equal to or less than 30 mA.

Warning!
If the power cable is damaged, it must be replaced by the manufacturer, by an authorized technical assistance provider or else by an individual with similar qualifications, in order to prevent any risks.

EN 5 INSTALLATION

- This water dispenser can be equipped with a WATER BLOCK anti-flooding device (optional) to prevent any accidental water leaks (Fig. 13). Once the WATER BLOCK device has intervened, fitting **K** should be disassembled and button **P** pressed to reset the device.
- If instead of being connected directly to the aqueduct the machine is connected to an autoclave pump, then it is necessary to install above the water supply an ANTISHOCK device to prevent "water hammers" (Fig. 14).

5.4 DRAIN CONNECTION

The drain water is clean and it comes from the tray that collects any dripping during dispensing.

Connect the drain pipe (ext. $\varnothing 24\text{mm}$) to a drain with a drain-trap.

If necessary, cut the pipe so as to avoid constrictions or backflow problems.

5.5 HYGIENIC CLEANING

- Once you have checked that the appliance operates correctly, proceed with the "internal cleaning and hygienic cleaning" phase as described in chap. 6.

5.6 ELECTRICITY CONNECTION

Connection to the mains electricity supply is carried out by connecting the plug to a mains socket.

The supply socket must be equipped with an efficient earth plate and it must be sized for the load of the appliance (see technical characteristics).

Make sure that the mains voltage corresponds with what is specified on the data plate.

Make sure that there is an omnipolar switch above the socket with a minimum contact break of 3 mm protected by fuses of suitable amperage for the absorption of the appliance itself (see technical characteristics and data plate).

- Turn the cold water regulator screw **F** (Fig. 15) (4 to 7 positions are advised).

16

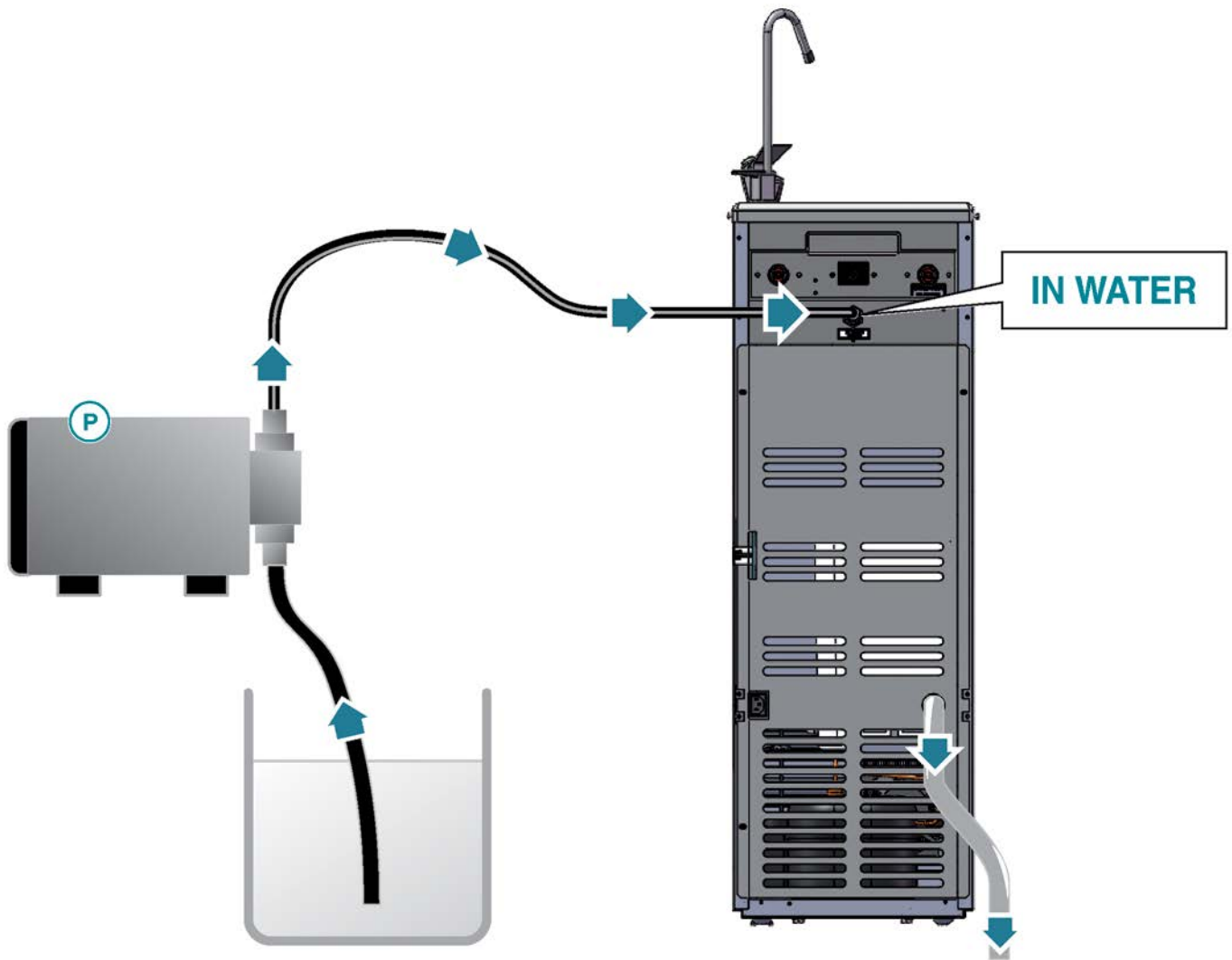

EN 6 INTERNAL CLEANING/ HYGIENIC CLEANING

WARNING! Considering that the products used for the hygienic cleaning are acid and alkali corrosive substances, disposable gloves must be used as well as glasses to protect your eyes. When this hygienic cleaning is carried out, you must keep to the product reaction times, percentages of hygienic detergent and quantity of water necessary for rinsing.

- The operation of higienization/sterilization has to be carried out every time the refrigerator is installed and:
 - every 6 months when it is used (*);
 - every time the water filter is changed;
 - after an inoperative period of one or more weeks.

(*) If the refrigerator is installed in Hospitals, Schools, Old people's homes, or Clinics, it is recommended to sterilize it every 3 months.

Hygienic cleaning solution preparation:

- Prepare 5 litres of water.
- Add to it 5% of "hydrogen peroxide" at 100 volumes; for the doses, use a graded measure or an ordinary syringe.

NB: if you use commercial hygienic cleaning solutions, keep to the instructions provided by the manufacturer and included in the package.

Warning! If the appliance is equipped with a chlorine filter, proceed as follows: Remove the filter cartridge and fit on the false cartridge mod. TEST CAN.

- With the help of a pump P, connect the appliance's water inlet to the container with the disinfecting solution.
- Start the pump, letting this solution into the appliance and then at the same time opening the taps so as to let all the hygienic cleaning solution flow out from both the dispensing spouts.
- Before the solution runs out, stop the pump and interrupt the dispensing.
- Leave the solution to do its work for minimum 20 minutes.
- Reconnect the appliance to the mains water supply.
- Let at least 15 litres of water flow out of the taps so as to rinse the hydraulic system suitably, before using the appliance again.

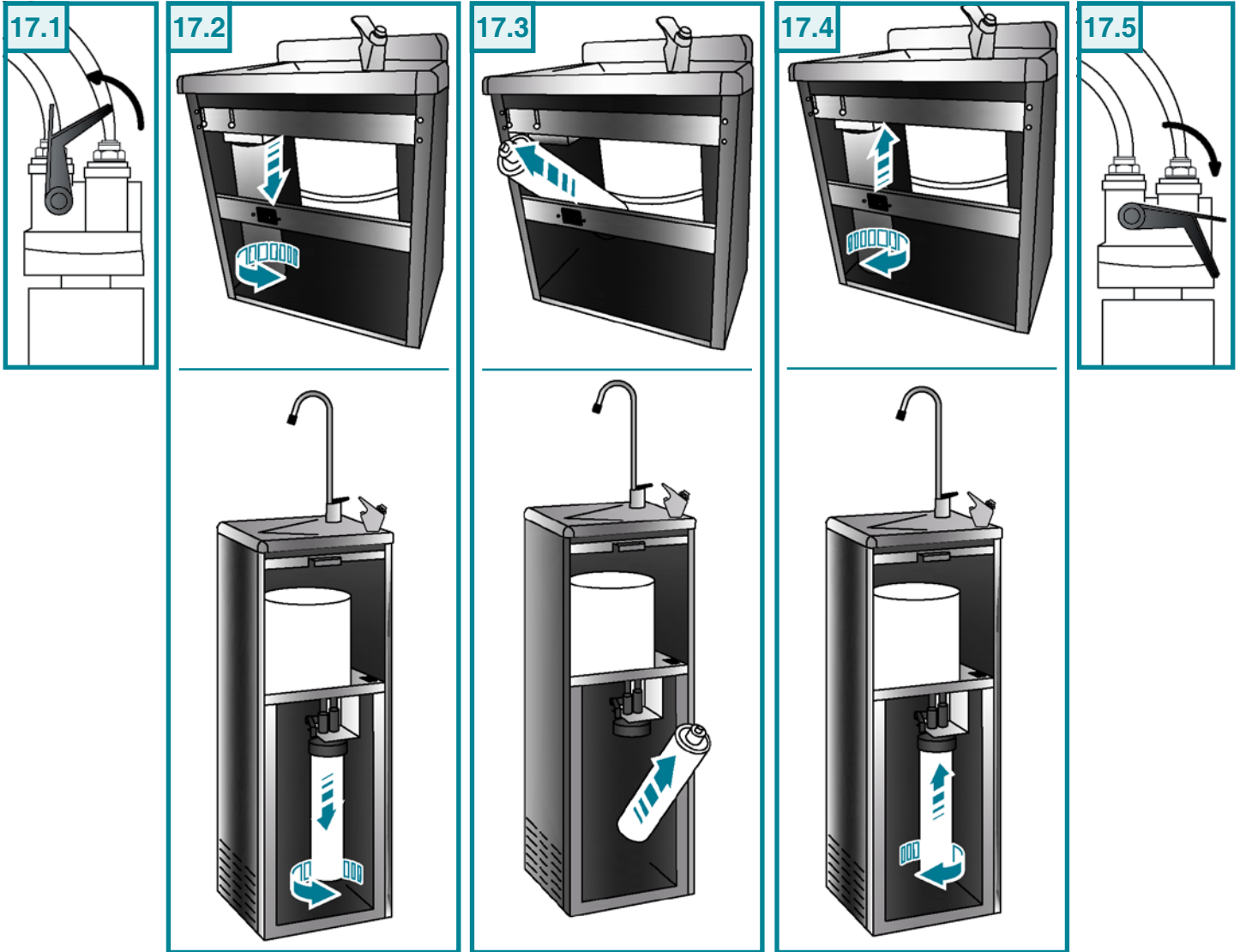

EN 7 HOW TO REPLACE THE FILTER CARTRIDGE



Attention! to carry out this or any other maintenance operation requiring the machine casing to be opened, use protective gloves to avoid being cut by sharp edges of the sheet steel.

The Water filter must be replaced one time per year or at least every six months, if the water flow decreases.

- Open the Front door
- Put the lever in vertical position to stop the water (Fig. 17.1).
- Turn cartridge slowly, until it stops (Fig. 17.2)
- Pull used cartridge straight down and extract from the cooler (Fig. 17.2 - 17.3).

- There may be a small amount of water during cartridge removal.
- Push the new cartridge into filter head and turn until it stops (Fig. 17.4).
- Turn the lever in horizontal position and check if there're water leaks (Fig. 17.5).
- Flush the new cartridge for two minutes expelling any trapped air and carbon fines. Water may run cloudy with air but will quickly clear.



This work, is reserved to a qualified operator.

**Warning!** The operations should be carried out by a qualified professional.

8.1 DIAGNOSIS AND OPERATING ANOMALIES

This section includes the typical anomalies that could occur.

Many of these problems are not caused by the cooler, but they could be brought about by the electricity supply or by an incorrect use of the water cooler.

In the ANOMALY column, the problems report by the customer are listed.

In the POSSIBLE CAUSES column, the "probable reasons" behind the problem are listed.

In the INTERVENTION column, the corresponding corrective action is listed.

8.2 COOLING SYSTEM

ANOMALY	POSSIBLE CAUSE	INTERVENTION
The compressor will not start.	Power failure.	Check that there is voltage in the plug.
	Thermostat on the off position, or set to the minimum.	Adjust the thermostat position.
	Faulty thermostat.	Replace the thermostat.
	The over-load protection of the compressor is faulty.	Replace it.
	The starting relay is faulty.	Replace it.
	The starting capacitor is faulty.	Replace it.
	The compressor is faulty	Replace it.
The water is cold but the appliance is operating excessively or non-stop.	Little ventilation.	Place the appliance away from the wall.
	The condenser is dirty or covered.	Clean the condenser or free it of its obstacles.
	The thermostat is on maximum cold position.	Adjust it.
	The room temperature is higher than 32°C.	It is normal that the appliance works at a continuously high room temperature.
The compressor works continuously, but the water is not cold.	Gas leak from the cooling system.	Contact a specialised technician (Refrigerationist).
	The compressor is faulty.	Replace the compressor.
COOLING SYSTEM		
Too much noise coming from the appliance, but it is working normally.	The machine is not levelled.	Level the appliance using the adjustable feet.
	A few pipes are touching some parts inside the appliance, thus causing it to vibrate.	Adjust the position of the pipes, making sure they do not touch any other parts.
Could water comes out slowly or not all.	Low pressure of the inlet water.	Take steps to increase the pressure (autoclave).
	Faulty solenoid valve.	Replace it.
	Clogged water filter.	Replace it.
	The temperature adjuster is faulty and causes complete freezing of the ice compartment.	Make the ice melt. Replace the temperature adjuster.

Qualified operator service:

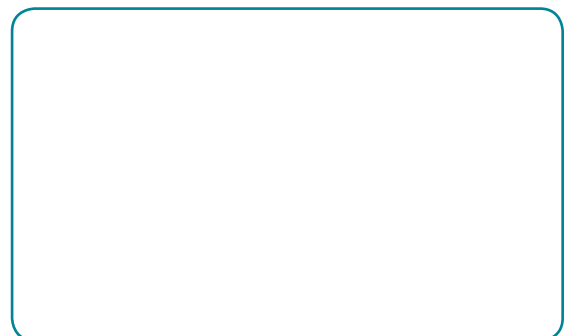

The dealer / Installer has to mark this square for the service.